



MULTISTONE™
TILES



New Multi Tech +

DOUBLE

C H A R G E

600x600mm



MULTISTONE™
TILES

EVOCATIVE SURFACE

We has come up with the classic Glossy finish tiles. With glistening surface and charming elegance, these tiles have been forged with so much of glamour and desire. Admire the overflow of grandeur shimmering throughout the tile patterns.





Architectural

spaces

For your Dream Home...

Your home has been an architectural wonder because it is your dreams come true! Such personal and private spaces open up when friends and family join in. Your deep emotions and feelings are attached to your surroundings. Our tiles are born out of empathy towards human behaviours. Pick them up to decorate your love-abode.



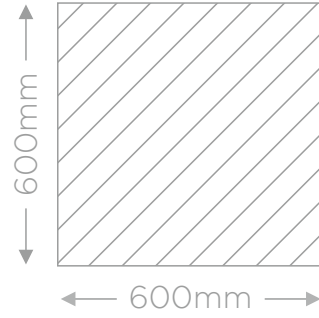
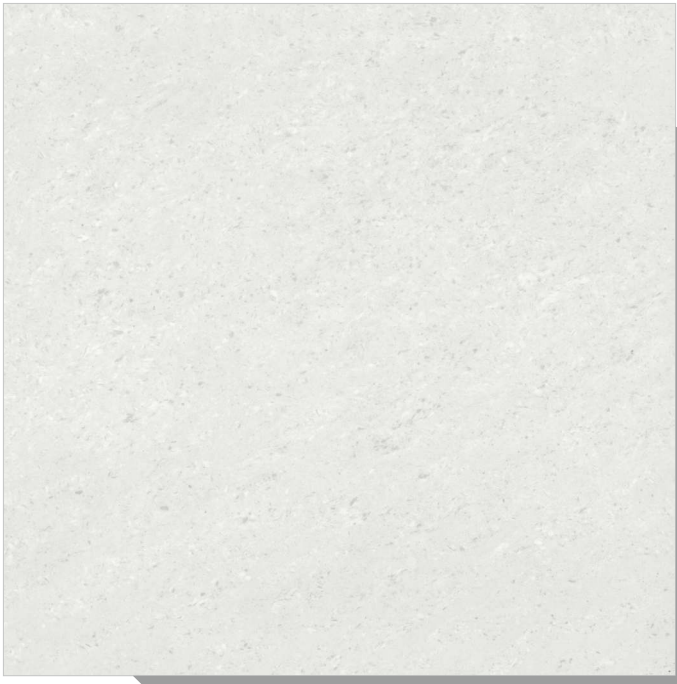

TROPICANA
WHITE



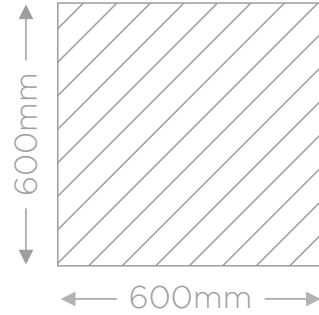

TROPICANA
BEIGE



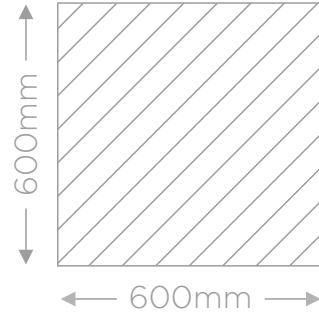
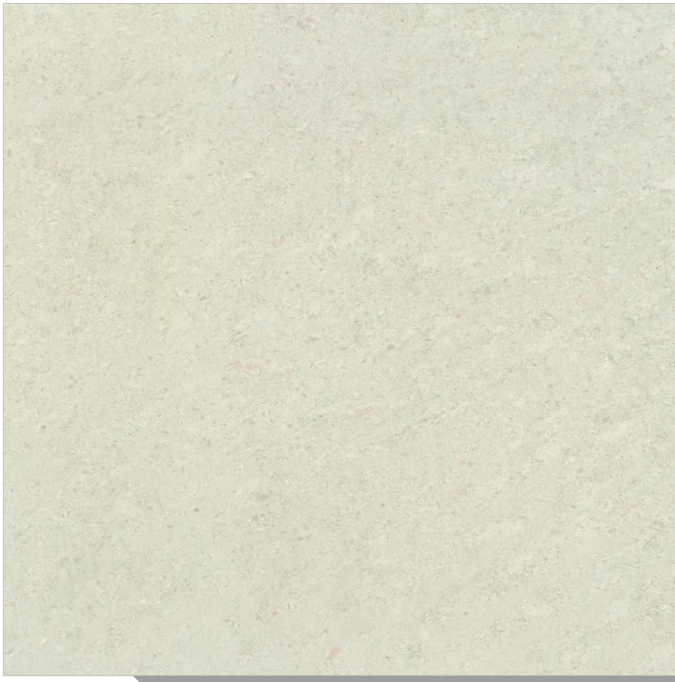

TROPICANA
PISTA



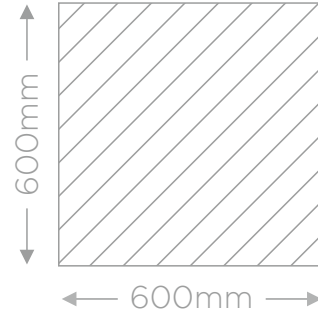

TROPICANA
ROSSA



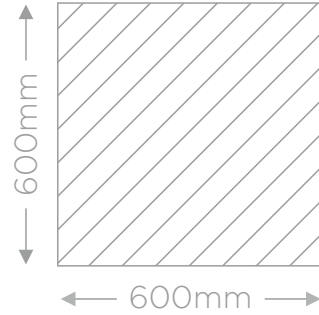
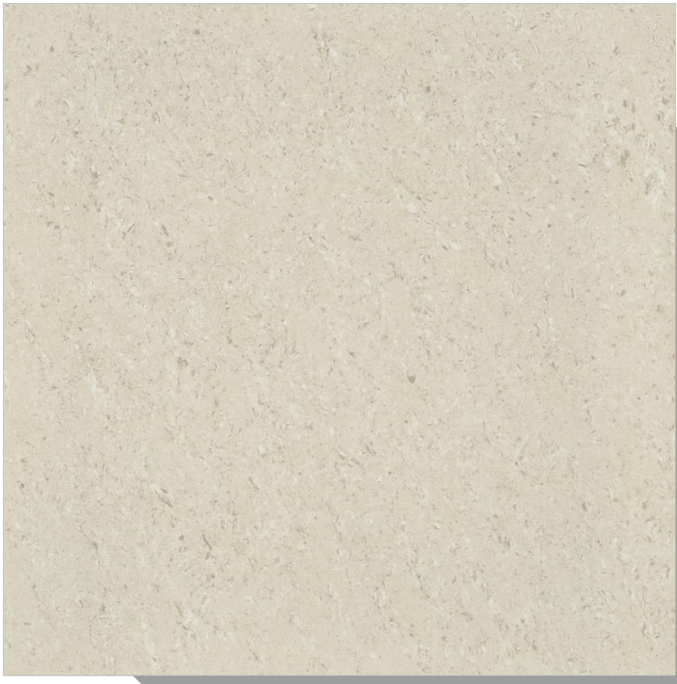

TROPICANA
OYSTER



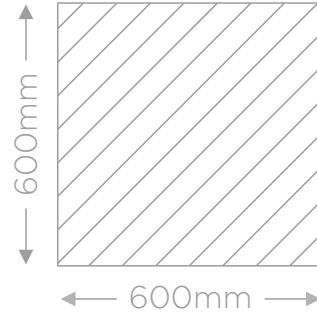
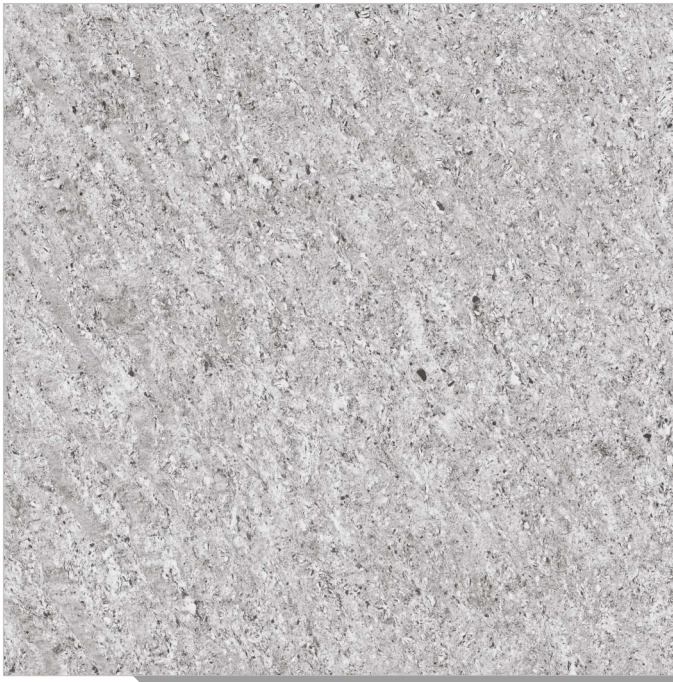

TROPICANA
OPERA



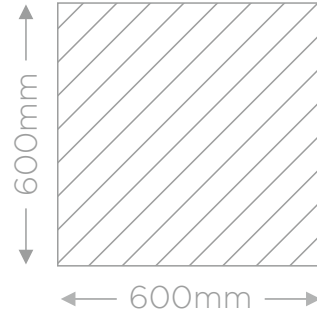

TROPICANA
ITALIAN



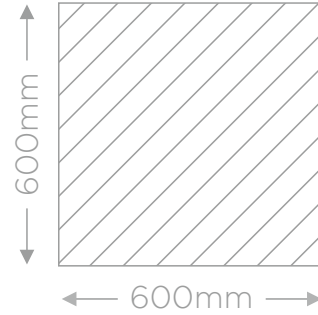

TROPICANA
GREEN AMBER



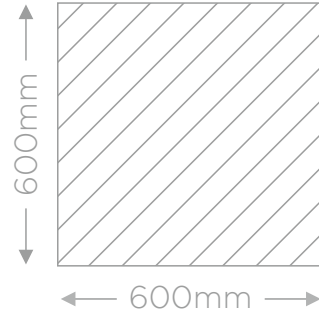

TROPICANA
RUBY



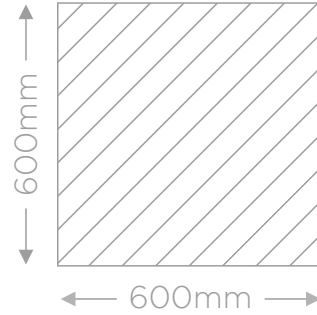

TROPICANA
SAND



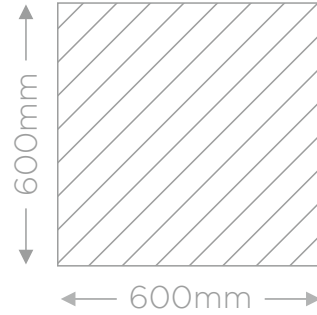

TROPICANA
STONE



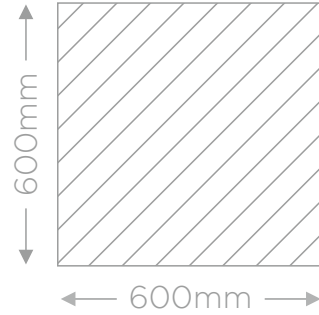

TROPICANA
THUNDER



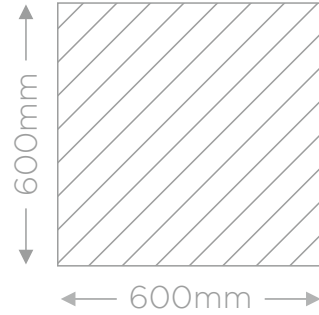
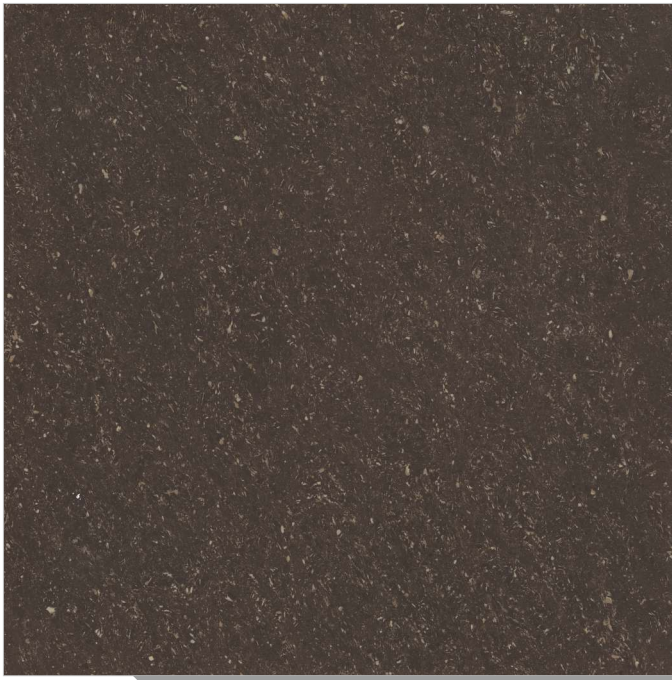

TROPICANA
CHOCO



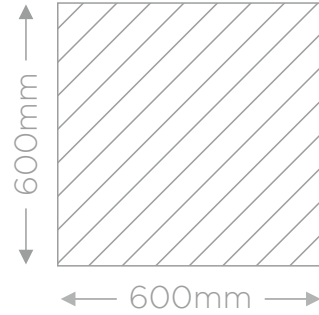
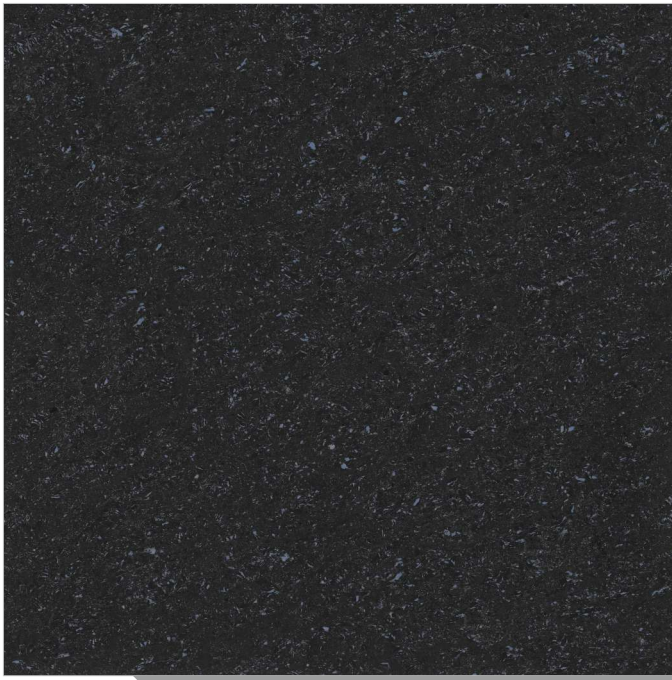

TROPICANA
GALAXY



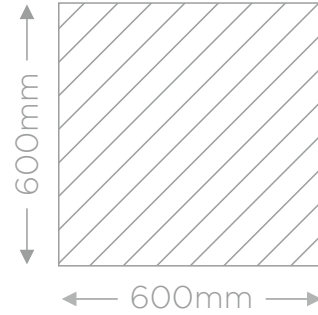

TROPICANA
WALNUT



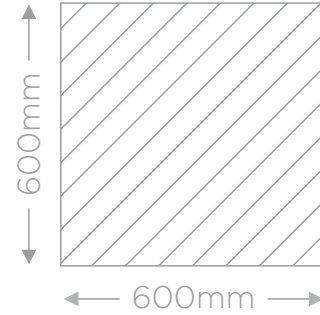
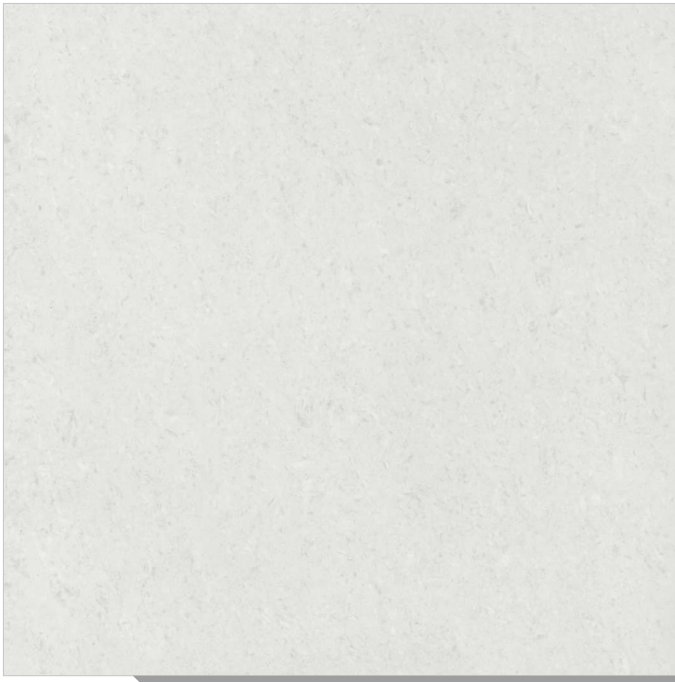

CARRARA
WHITE



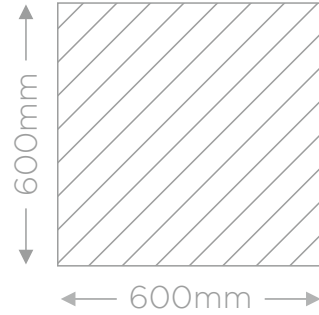
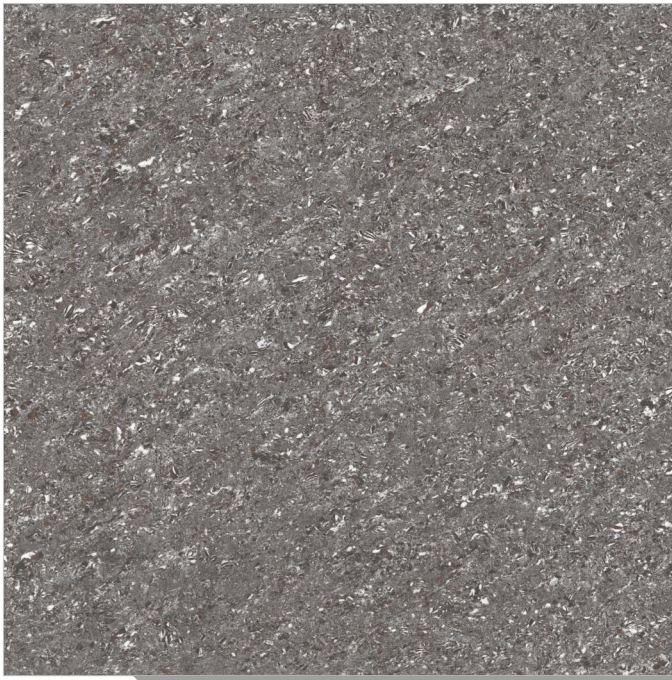

CARRARA
CHARCOAL



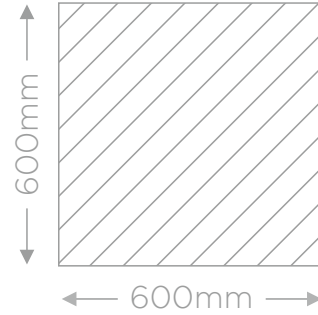

CARRARA
GRANITO



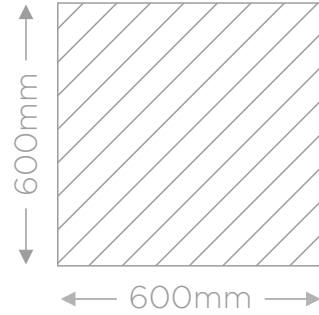
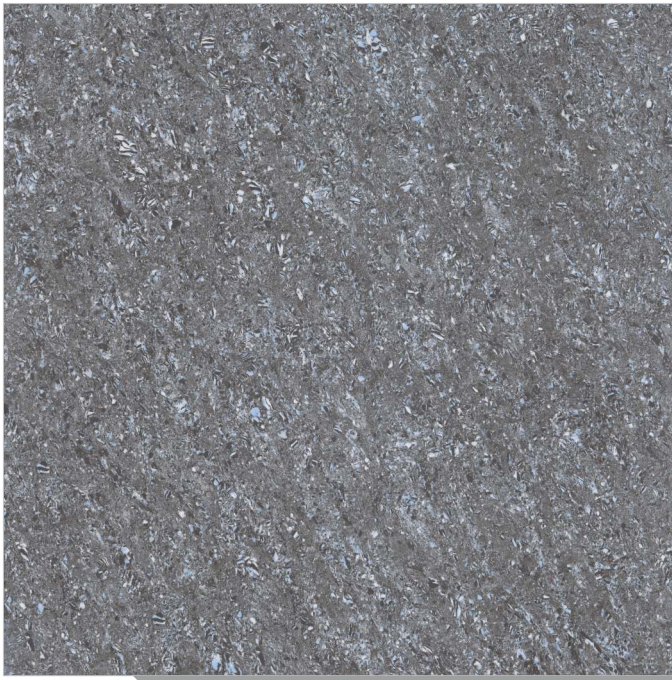

CARRARA
OCEAN



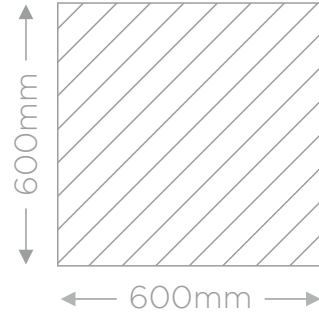

FUSION
BEIGE



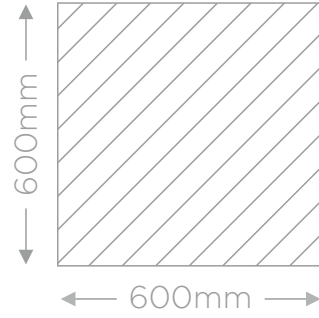

FUSION
WHITE



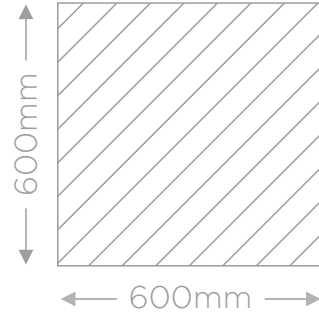

TYPHOON
BEIGE



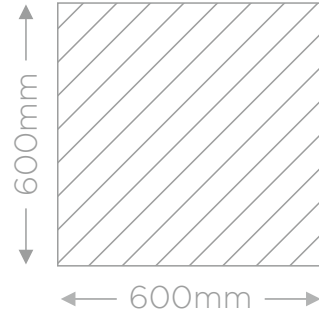

TYPHOON
WHITE





MULTISTONETM TILES

TECHNICAL SPECIFICATION OF DOUBLE CHARGE TILES

Sr No.	CHARACTERISTICS	TEST METHODS	IS 15622:2013 GROUP B I a	MULTISTONE VALUE
A	Dimension & Surface Quality			
1	Deviation in Length & Width	IS-13630-1	, +/- 0.1%	0.10%
2	Deviation in Thickness	IS-13630-1	, +/- -5.0%	3.50%
3	Straightness of Side	IS-13630-1	, +/- 0.1%	0.10%
4	Rectangularity	IS-13630-1	, +/- -0.1%	0.10%
5	Surface Flatness	IS-13630-1	, +/- 0.5%	0.20%
6	Surface Quality	IS-13630-1	95% of the Tiles Free From Visible Defect	95%
B	Physical Properties			
1	Water Absorption	IS-13630-2	<0.08%	0.06%
2	Modulus of Rupture	IS-13630-6	35 N/MM ²	40 N/MM ²
3	Flexure Braking Strength	IS-13630-6	>1300 N	>1700 N
4	Moisture Expansion	IS-13630-3	0.02%	Nil
5	Scratch Hardness (Moh's)	IS-13630-13	Min-5	3/4*
6	Resistance of Deep Abrasion	IS-13630-11	Max. 140 Mm ³	125 MM ³
7	Thermal Expansion	IS-13630-4	6 x 10 ⁻⁶ K ⁻¹	6 x 10 ⁻⁶ K ⁻¹
8	Thermal Shock Resistance	IS-13630-5	Min 10 Cycle	10 Cycle Passed
9	Frost Resistance	IS-13630-10	No Damage	No Damage
10	Bulk Density	IS-13630-2	>2.2gm/cc	2.3 gm/cc
11	Glossiness	Gloss meter	As Per Mfg. Norms.	>85%
C	Chemical Properties			
1	Resistance to Staining	IS-13630-8	Class I Min.	Class II
2	Household Chemicals	IS-13630-8	Class AA Min.	Class AA
3	Acid Resistance	IS-13630-8	Resistance	Resistance

NOTE

Colours shown are as accurate as the limitations of the printing process will allow. Prospective customers are advised to inspect a sample of the tile before ordering. Every effort has been made to ensure the accuracy of the information given. However, the company reserves the right to change the specifications without prior notice. Sometimes variations in shade or size being inherent to ceramic industry may occur. Before fixing, we advice you to follow the fixing instruction on the cartons of the tiles as no responsibility can be accepted by the company once the tiles have been fixed.

APPLICATIONS



AIRPORT TERMINALS



DISCOTHEQUES



HOSPITALS



DOMESTIC



INDUSTRIES



SCHOOLS



SUPER MARKETS



CORRIDORS/HALLS



GYMNASIUMS



RESTAURANTS-CAFES



SHOPPING MALLS



HOTELS



OFFICES



RELIGIOUS PLACES



MULTISTONE™
TILES



MULTISTONE GRANITO PVT. LTD.

**Factory Add. : N.H. 8-A, Lunsar Road, Nr. Bhojalpara, G.E.B. Sub Station,
Wankaner - 363621 (Gujarat) INDIA**

© +91 70692 90020 +91 99099 55161 +91 82006 52231

✉ sales@multistonetiles.com 🌐 www.multistone.in